

INSTALLATION INSTRUCTIONS FOR FIELD ASSEMBLY OF TAPER THREADED GRIP-TWIST® STRUCTURAL CONNECTOR

FABRICATOR IS RESPONSIBLE FOR PROVIDING THESE INSTRUCTIONS TO THE PLACER AND/OR CONTRACTOR.

Taper Threaded Grip-Twist® Male couplers and Structural Connectors are shipped with color-coded plastic caps and plugs to protect the threads. These should be kept in place until time of assembly. If missing, obtain the correct caps and/or plugs from the manufacturer. If thread damage is discovered, it must be corrected before assembly to avoid premature binding. Minor thread damage can be fixed using a thread file, or a thread cleaning tool. **DO NOT TRY TO ASSEMBLE DAMAGED THREADS.** All Structural Connectors and Male couplers are marked with the intended rebar size. Take care to install the correct size connector on the corresponding size Male coupler. **DO NOT USE WITH REBAR THAT IS LARGER OR SMALLER THAN THE INTENDED SIZE.** STORE CONNECTORS AND MALE COUPLERS IN A CLEAN, DRY PLACE UNTIL READY TO INSTALL.

CAUTION: Remove plastic PLUG in Structural Connector prior to welding. If installing in stages, be sure to reinstall the plug in the Structural Connector after welding (when connector has cooled to ambient temperature) to protect the threads until it is time to assemble the Male coupler. Weld surfaces should be cleaned as needed

- Using electrode **E7018** (or equivalent for low carbon steel, Grade 1018) fillet weld entire circumference of the Structural Connector using weld bevel size "W" as shown in **FIGURE 1**. Welding to conform to AWS D1.1, Structural Welding Code. **DO NOT WELD CONNECTOR IN PLACE IF THE THREADS ARE DAMAGED AND CANNOT BE REPAIRED.**

FIGURE 1: WELDING STRUCTURAL CONNECTOR

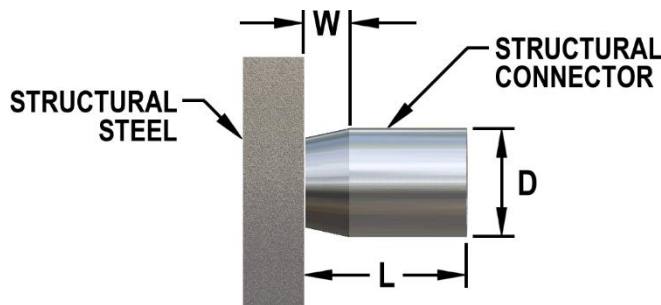

REBAR SIZE US (metric) [CAN]	STR. CONN. LENGTH "L" (in)	STR. CONN. DIAMETER "D" (in)	WELD BEVEL SIZE "W" (in)
#4 (13) [10M]	1 3/8	7/8	3/16
#5 (16) [15M]	1 11/16	1 1/16	1/4
#6 (19) [20M]	2	1 3/8	1/4
#7 (22)	2 5/16	1 9/16	5/16
#8 (25) [25M]	2 5/8	1 3/4	3/8
#9 (28) [30M]	3	1 15/16	7/16
#10 (32)	3 3/8	2 3/16	1/2
#11 (36) [35M]	3 5/8	2 3/8	9/16
#14 (43) [45M]	4 3/8	2 7/8	11/16
#18 (57) [55M]	5 3/4	3 15/16	7/8
#20 (64)	6 5/8	4 9/16	1

- Remove the protective cap from the TTGT Male coupler and check both external (Male) and internal (Structural Connector) threads for cleanliness. Clean off any debris and/or foreign matter. **DO NOT USE CORROSIVE ACIDS.** Any thread damage must be corrected as noted above prior to installation.
- Locate the Male coupler and Structural Connector, and line them up as straight as possible. See **FIGURE 2** for pre-assembled connection. Align the COUPLER and CONNECTOR so that the threads will screw together without binding.

FIGURE 2: PREASSEMBLED CONNECTION

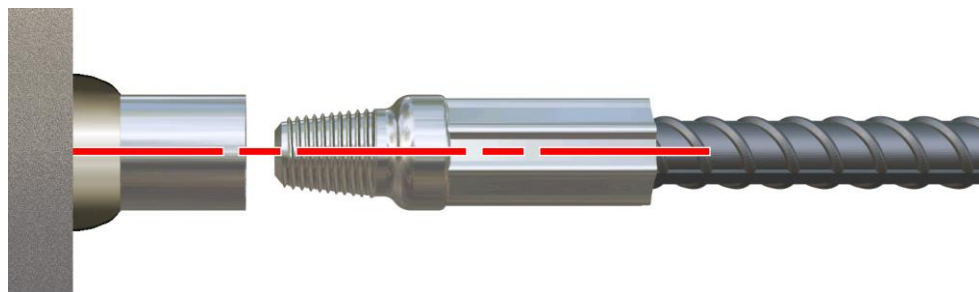

- 4) After the initial thread location, rotate the free rebar clockwise making sure the two halves remain aligned. If you feel the threads starting to prematurely bind, **DO NOT FORCE THEM**. Shake the free end of the rebar while turning, allowing the free end of the rebar to rotate in its own natural circle with the coupler threads aligned. Continue to rotate (approximately 4 – 5 rotations) until **FULLY ENGAGED** and **SNUG**. See **FIGURE 3** for assembled connection.

FIGURE 3: ASSEMBLED CONNECTION



NOTE: If the Male threads do not properly engage the Structural Connector during assembly, stop immediately. Disassemble the connection to determine the problem. Possible causes of mis-assembly may be mis-matched thread sizes, contaminated threads (i.e. concrete, dirt, etc.) or damaged threads. Re-assemble only after the problem has been identified and corrected.

- 5) A chain wrench or pipe wrench can be used to snug and tighten the Male coupler and Structural Connector as needed. Always consider your own **personal safety**. Make sure you are securely positioned and that you will not slip or fall during installation. Use only good quality wrenches that will not round-out.

NOTE: Long lengths of rebar, especially large diameter bars, are heavy. To overcome rebar weight, it may be necessary to use an extension bar. As necessary, use the following wrench lengths as a guide: Bar sizes #3 - #6 (10-19 mm) = 8 - 12" (20-30 cm) length; Sizes #7 - #8 (22-25 mm) = 12 - 18" (30-45 cm) length; Sizes #9 - #11 (29 - 36 mm) = 18 - 24" (45-60 cm) length; and Sizes #12 - #20 (38-64 mm) = 24-36" (60-90 cm) length. **DO NOT WIRE TIE BARS UNTIL AFTER FULL ASSEMBLY.**

- 6) After assembly, inspect for complete swaging of the Male coupler and proper thread engagement. For taper threads, some variation in the number of exposed threads is natural due to the thread tolerance and run-out. In general, it is typical to see 0 to 1 complete thread(s) after full assembly, per **FIGURE 3**. If needed, fully assembled taper threads can be double-checked by the application of a chain wrench or pipe wrench as described above, to ensure the couplers are snug. **IT IS NOT NECESSARY TO USE A TORQUE WRENCH OR APPLY A HIGH TORQUE VALUE.**