



Originally Issued: 10/04/2021

Revised: 10/21/2024

Valid Through: 10/31/2026

BARSPLICE PRODUCTS, INC.
4900 Webster Street
Dayton, OH 45414
937-275-8700
www.barsplice.com

BARSPLICE PRODUCTS, INC. MECHANICAL SPLICE SYSTEMS FOR STEEL REINFORCING BARS:

- **BARGRIP (BPI-GRIP) XL
TRANSITION BARGRIP XL**
- **TAPER THREADED GRIP-TWIST®
TRANSITION TAPER THREADED
GRIP-TWIST®
POSITION TAPER THREADED GRIP-
TWIST®**
- **BARSPLICER XP**
- **ZAP SCREWLOK® TYPE 2
TRANSITION ZAP SCREWLOK®
ZAP SCREWLOK® FX**

CSI Section:

03 21 00 Reinforcing Steel

1.0 RECOGNITION

The Barsplice Products, Inc. Mechanical Splice Systems recognized in this report have been evaluated for use as mechanical splices for deformed steel reinforcing bars (rebar) in reinforced concrete structural members. The structural properties of the Barsplice Products Mechanical Splice Systems comply with the intent of the provisions of the following codes and regulations:

- 2021, 2018, 2015, 2012, and 2009 International Building Code® (IBC)
- 2021, 2018, 2015, 2012, and 2009 International Residential Code® (IRC)
- 2022 and 2019 California Building Code (CBC) – attached Supplement
- 2022 and 2019 California Residential Code (CRC) – attached Supplement
- 2020 City of Los Angeles Building Code (LABC) – attached Supplement
- 2020 City of Los Angeles Residential Code (LARC) – attached Supplement

2.0 LIMITATIONS

Use of the Barsplice Products, Inc. Mechanical Splice Systems recognized in this report is subject to the following limitations:

2.1 The Barsplice Products, Inc. Mechanical Splice Systems shall be installed in accordance with the applicable code, the manufacturer's instructions, and this report. In the event of a conflict, the more restrictive governs.

2.2 Under the 2021 IBC or IRC, mechanical splice systems used in special moment frames (SMF), SMF constructed of precast concrete, special structural walls, intermediate structural wall connections, and other applicable structures are only allowed as permitted in Chapter 18 of ACI 318-19, and as described in Sections 2.3 to 2.7 of this report.

2.3 Under the 2021 IBC or IRC, only Type 2 mechanical splices of ASTM A706 Grade 60 reinforcement, or ASTM A615 Grade 60 reinforcement satisfying the requirements of ACI 318-19 Section 20.2.2.5(b), shall be permitted in regions where plastic hinging may occur, and located within a distance equal to twice the member depth from the column or beam face for special moment frames or from critical sections where yielding of the rebar occurs as a result of lateral displacements beyond the linear range of behavior in accordance with ACI 318-19 18.2.7.2. It is unknown if mechanical splices of other grades of steel reinforcement in special moment frames and special structural walls are capable of resisting stress levels expected in yielding regions in accordance with ACI 318-19 R18.2.7 and this use is beyond the scope of this report.

2.4 Under the 2021 IBC or IRC, the ability of the included mechanical splice systems, when used on Grade 75 or Grade 80 reinforcement, to resist forces and provide yielding in the vicinity of the intermediate precast structural wall connections between precast wall panels, or between wall panels and the foundation, in the plastic region in accordance with ACI 318-19 R18.5, has not been determined, and this use is beyond the scope of this report.

2.5 Under the IBC or IRC, mechanical splice systems used in special moment frames constructed using precast concrete are expected to experience flexural yielding in connection regions in accordance with ACI 318-19 and -14 R18.9 (ACI 318-11 and -08 R21.8), and this use is beyond the scope of this report.

2.6 Under the 2021 IBC or IRC, mechanical splices of Grade 80 reinforcement shall not be used to transfer forces between the diaphragm and the vertical elements of the seismic-force-resisting system in accordance with ACI 318-19 18.12.7.4.

2.7 Under the 2021, 2018, and 2015 IBC or IRC, deformed steel reinforcing bars used with the Barsplice Products, Inc. Mechanical Splice Systems shall comply with ACI 318-19 and -14 Section 20.2.2.4 and Table 20.2.2.4(a) for the intended structural usage and application.

2.8 Under the 2021 IBC or IRC, for structures regulated by Chapter 18 of ACI 318-19 (as required by 2021 IBC Section 1905.1), to splice deformed steel reinforcing bars resisting earthquake-induced moment, axial force, or both, in special seismic systems and anchor reinforcement in Seismic Design

The product described in this Uniform Evaluation Service (UES) Report has been evaluated as an alternative material, design or method of construction in order to satisfy and comply with the intent of the provision of the code, as noted in this report, and for at least equivalence to that prescribed in the code in quality, strength, effectiveness, fire resistance, durability and safety, as applicable, in accordance with IBC Section 104.11. This document shall only be reproduced in its entirety.





Categories (SDC) C, D, E, and F, with the Barsplice Products, Inc. Mechanical Splice Systems, mill certificates of the steel reinforcing bars shall be submitted to the building official as evidence of compliance with ACI 318-19 Section 20.2.2.5.

2.9 Under the 2018 IBC or IRC, for structures regulated by Chapter 18 of ACI 318-14 (as required by 2018 IBC Section 1905.1), to splice deformed steel reinforcing bars resisting earthquake-induced flexure, axial force, or both, in special moment frames, special structural walls, and all components of special structural walls including coupling beams and wall piers, with the Barsplice Products, Inc. Mechanical Splice Systems, mill certificates of the steel reinforcing bars shall be submitted to the building official as evidence of compliance with ACI 318-14 Section 20.2.2.5.

2.10 Under the 2015 IBC, for structures regulated by Chapter 18 of ACI 318-14 (as required by 2015 IBC Section 1905.1), to splice deformed steel reinforcing bars resisting earthquake-induced moment, axial force, or both, in special moment frames, special structural walls, and all components of special structural walls including coupling beams and wall piers, with the Barsplice Products, Inc. Mechanical Splice Systems, mill certificates of the steel reinforcing bars shall be submitted to the building official as evidence of compliance with ACI 318-14 Section 20.2.2.5.

2.11 Under the 2012 IBC, for structures regulated by Chapter 21 of ACI 318-11 (as required by 2012 IBC Section 1905.1), to splice deformed steel reinforcing bars resisting earthquake-induced flexure, axial force, or both, in special moment frames, special structural walls, and all components of special structural walls including coupling beams and wall piers, with the Barsplice Products, Inc. Mechanical Splice Systems, mill certificates of the steel reinforcing bars shall be submitted to the building official as evidence of compliance with ACI 318-11 Section 21.1.5.2.

2.12 Under the 2009 IBC, for structures regulated by Chapter 21 of ACI 318-08 (as required by 2009 IBC Section 1908.1), to splice deformed steel reinforcing bars resisting earthquake-induced flexural and axial forces in frame members, structural walls, and coupling beams, with the Barsplice Products, Inc. Mechanical Splice Systems, mill certificates of the steel reinforcing bars shall be submitted to the building official as evidence of compliance with ACI 318-08 Section 21.1.5.2.

2.13 Splice locations and rebar placement shall comply with applicable code requirements and be noted on plans approved by the building official.

2.14 Special inspections shall be provided in compliance with Section 3.4 of this report.

2.15 For mechanical splice couplers swaged onto steel bars at the job site, fabricators shall conform to the following conditions:

1. The job site fabricator shall be approved by Barsplice Products, Inc. representative.
2. The job site fabricator shall demonstrate the following items to the satisfaction of the special inspector for each coupler model type and steel reinforcing bar size:
 - a. The fabricator assembles the couplers onto the ends of the steel reinforcing bar as required by Barsplice Products, Inc. in a manner consistent with the qualifying test specimens. Section 3.3 of this report provides further installation details.
 - b. For Type 2 splices, splices using the fabricator-prepared assemblies of couplers and steel reinforcing bars, tested in static tension, shall develop 100 percent of the specified tensile strength of the steel reinforcing bar and 125 percent of the specified yield strength of the reinforcing bar for use under the IBC or IRC. Evidence of compliance may be demonstrated by test reports submitted to the building official. These tests should be conducted prior to commencement, and periodically throughout the duration, of the job site assembly of the couplers onto the ends of the steel reinforcing bars. The frequency of the tensile tests shall be acceptable to the registered design professional for the building project, and the applicable building official.
 - c. For Type 1 splices, splices using the fabricator-prepared couplers and steel reinforcing bars, tested in static tension, shall develop 125 percent of the specified yield strength of the reinforcing bar. Evidence of compliance may be demonstrated by test reports submitted to the building official. These tests should be conducted prior to commencement, and periodically throughout the duration, of the job site assembly of the couplers onto the ends of the steel reinforcing bars. The frequency of the tensile tests shall be acceptable to the registered design professional for the building project, and to the applicable building official.

2.16 For mechanical splice couplers swaged onto steel bars at shop facilities of fabricators not identified in this report, fabricators shall conform to the following requirements:

1. The fabricator shall be approved by the building official in accordance with Section 1704.2.5.1 of the 2021, 2018, and 2015 IBC (Section 1704.2.5.2 of the 2012 IBC or Section 1704.2.2 of the 2009 IBC, as applicable).
2. The fabricator shall be approved by authorized personnel of Barsplice Products, Inc.
3. The fabricator shall assemble the couplers onto the ends of the steel reinforcing bar as required by Barsplice Products, Inc. in a manner consistent with the qualifying test specimens. Section 3.3 of this report provides further installation details.
4. For Type 2 splices, splices using the fabricator-prepared assemblies of couplers and steel reinforcing



bars, tested in static tension, shall develop 100 percent of the specified tensile strength of the steel reinforcing bar and 125 percent of the specified yield strength of the reinforcing bar for use under the IBC or IRC. Evidence of compliance may be demonstrated by test reports submitted to the building official.

5. For Type 1 splices, splices using the fabricator-prepared assemblies of couplers and steel reinforcing bars, tested in static tension, shall develop 125 percent of the specified yield strength of the reinforcing bar. Evidence of compliance may be demonstrated by test reports submitted to the building official.

2.17 The Barsplice Products, Inc. Mechanical Splice Systems are produced in Dayton, Ohio.

3.0 PRODUCT USE

3.1 General: Barsplice Products, Inc. Mechanical Splice Systems are used to mechanically splice deformed steel reinforcing bars (rebars) installed in concrete structural members. The splice systems recognized in this report conform to Section 25.5.7.1 and Section 18.2.7.1 of ACI 318-19 and -14 (Section 12.14.3 and 21.1.6 of ACI 318-11), for use as tension and compression mechanical splices for deformed steel reinforcing bars. The recognized splice systems comply with the requirements of Section 18.2.7.1 of ACI 318-19 and -14 for the 2021, 2018, and 2015 IBC (Section 21.1.6.1 of ACI 318-11 for the 2012 IBC, and ACI 318-08 for the 2009 IBC) as Type 1 and Type 2 mechanical splices. When used as Type 2 mechanical splices for Grade 60 reinforcement, the recognized splice systems are permitted within the concrete structural member, as allowed by the IBC, IRC, and ACI 318, in all seismic design categories.

3.2 Design: The Barsplice Products, Inc. Mechanical Splice Systems shall be installed in accordance with the IBC, ACI 318, this evaluation report, and the manufacturer's published installation instructions. Where conflicts occur the more restrictive shall govern. The locations of splices shall be detailed on the plans and approved by the building official. The minimum concrete cover and spacing shall be in accordance with IBC Chapters 7 and 19, ACI 318-19 Section 20.5.1, ACI 318-14 Section 20.6.1, or ACI 318-11, and -08 Section 7.7, and shall be measured from the outer surface of the splice system or as defined by the registered design professional. Under the 2021 IBC and IRC, the use of the Barsplice Mechanical Splice Systems in members and structural systems is limited to what is allowed in Section 18.2.7.2 of ACI 318-19.

3.3 Installation: Copies of Barsplice Products, Inc. installation instructions shall be supplied with each order, and assembly instructions for the manufacturer's mechanical splice systems, are available from Barsplice, or through the following link: <https://www.barsplice.com/technical-information.html#installation-instructions>.

3.3.1 BarGrip XL: The BarGrip XL System, including the standard BarGrip XL coupler and BarGrip XL Transition coupler, may be either installed partially in a fabricator's shop and then completed in the field, or fully installed in the field at a job site. When installed, the steel reinforcing bar shall be marked and inserted halfway into one end of the coupling sleeve on the first side, where it shall be swaged onto the bar. The insertion and the swaging processes are then repeated on the second side. Additional details are included in the manufacturer's installation instructions provided in Section 3.3 of this report.

3.3.2 Taper Threaded Grip-Twist® System: The Taper Threaded Grip-Twist System, including the standard Grip-Twist coupler, Transition Grip-Twist coupler, and Position Grip-Twist coupler, is installed on the reinforcing bar ends in a fabricator's shop and then fully assembled in the field. The first reinforcing bar end shall be inserted the required depth into the coupler, before swaging the coupler onto the bar. The process is repeated for the second coupler on the second bar end. These couplers are then assembled in the field. All threads of the couplers shall be free of debris at the time of assembly. A pipe wrench may be used to snugly secure the splice system. Additional details are included in the manufacturer's installation instructions provided in Section 3.3 of this report.

3.3.3 BarSplicer XP: The BarSplicer XP System is shipped with bar ends threaded by Barsplice, with couplers already in place on one of the bar ends. These bars are either cast in concrete with the coupler attached to the form face or tied in place in a slab. Upon completion of the concrete pour and removal of the formwork, or to extend the existing laid slab, the second threaded reinforcing bar is installed into the coupler and rotated until the bar no longer turns. All threads of the coupler and bar ends shall be free of debris at the time of assembly. A pipe wrench may be used to snugly fit and secure the splice system. Additional details are included in the manufacturer's installation instructions provided in Section 3.3 of this report.

3.3.4 Zap Screwlok®: The Zap Screwlok Splice System, including the Zap Screwlok Type 2, Transition, and FX couplers, is installed in the field. All oil, dirt, moisture, and other debris shall be removed from the coupler and the reinforcing bar ends. The first bar is inserted on one side of the coupler sleeve until contact is made with the center pin. The screws are then tightened from the outside to the center of the sleeve with an impact wrench until the heads shear off. The second bar is inserted into the other side until it contacts the center pin, and the screw installation procedure is repeated on the second side. If the coupler is specially supplied without a center stop, or if the center stop is removed, measure and mark the rebar for one-half of the coupler length (L/2) before inserting it into the coupler. Additional details are found in the manufacturer's published installation instructions provided in Section 3.3 of this report.



3.4 Special Inspection: Special inspection of the Barsplice Products, Inc. Mechanical Splice Systems shall be provided at the job site as required by Section 1705 of the 2021, 2018, 2015, and 2012 IBC (Section 1704 of the 2009 IBC). In addition to verifying the installation of steel reinforcing bar splices in accordance with this report, the special inspector shall verify the grade and size of reinforcing bars, coupler identification, bar embedment length to couplers, position of couplers, placement of bar splices, as well as installation of the couplers to the reinforcing bars.

4.0 PRODUCT DESCRIPTION

4.1 BarGrip XL System: The BarGrip XL system consists of a seamless, steel sleeve that slips over the ends of the reinforcing bars being spliced. The BarGrip XL couplers, with dimensions shown in Table 1 and illustrated in Figure 1 of this report, are designed to mechanically join No. 4 through No.11, No.14, and No. 18 reinforcing bars. BarGrip XL Transition couplers, with dimensions shown in Table 2 and illustrated in Figure 2 of this report, are designed to join two dissimilar sizes of reinforcing bars.

4.1.1 Couplers: The BarGrip XL couplers are made from steel conforming with ASTM A519, Grades 1010 to 1026. The BarGrip XL Transition couplers are made from steel conforming with ASTM A576, Grade 1018.

4.1.2 Steel Reinforcing Bars: Deformed steel reinforcing bars shall be uncoated and comply with ASTM A615 Grade 60 or ASTM A706 Grade 60 specifications.

4.2 Taper Threaded Grip-Twist® System: The Taper Threaded Grip-Twist system consists of mating tapered threaded couplers assembled after each is swaged on the end of the reinforcing bars. The Tapered Threaded Grip-Twist standard couplers (available with and without a form-saving flange), with dimensions shown in Table 3 and illustrated in Figure 3 of this report, are designed to mechanically join No. 4 through No.11, No.14, and No. 18 reinforcing bars. Tapered Threaded Grip-Twist Transition couplers, with dimensions shown in Table 4 and illustrated in Figure 4 of this report, are designed to join two dissimilar sizes of reinforcing bars. Tapered Threaded Grip-Twist Position couplers, with dimensions shown in Table 5 and illustrated in Figure 5 of this report, are designed to join No. 8 through No.11, No.14, and No. 18 reinforcing bars.

4.2.1 Couplers: The Taper Threaded Grip-Twist couplers are made from steel conforming to ASTM A576, Grades 1018 to 1035.

4.2.2 Steel Reinforcing Bars: Deformed steel reinforcing bars shall be uncoated and comply with ASTM A615 Grade 60 or ASTM A706 Grade 60 specifications.

4.3 BarSplicer XP System: The BarSplicer XP system consists of three general components, including two pieces of reinforcing bar with external straight threads and a steel

coupler (available with and without a form-saving flange) with internal straight threads. The BarSplicer XP couplers are designed to join No. 4 through No.11 reinforcing bars with dimensions shown in Table 6 and Figure 6 of this report.

4.3.1 Couplers: The BarSplicer XP couplers are made from steel conforming to ASTM A108 Grades 1018 to 1215.

4.3.2 Steel Reinforcing Bars: Deformed steel reinforcing bars shall comply with ASTM A615 Grades 60, 75, and 80 or ASTM A706 Grades 60 and 80 specifications.

4.3.3 Coatings: Barsplicer XP couplers are available with an epoxy coating, and all grades of reinforcing bar may be epoxy coated in accordance with ASTM A775. Coating shall be applied prior to rebar threading or in a manner that will not interfere with proper thread engagement.

4.4 Zap Screwlok® System: The Zap Screwlok system consists of a steel coupling sleeve formed into a wedge and shear head screws with conical tips. The Zap Screwlok Type 2 couplers, with dimensions shown in Table 7 and illustrated in Figure 7 of this report, are designed to mechanically join No. 4 through No.11, No.14, and No. 18 reinforcing bars. Zap Screwlok Transition couplers, with dimensions shown in Table 8 and illustrated in Figure 8 of this report, are designed to join two dissimilar sizes of reinforcing bars. Zap Screwlok FX couplers, with dimensions shown in Table 9 and illustrated in Figure 9 of this report, are designed to join No. 11, No. 14, and No. 18 reinforcing bars.

4.4.1 Couplers: The Zap Screwlok couplers are formed from steel conforming to ASTM A519 Grades 1018 to 1026.

4.4.2 Steel Reinforcing Bars: Deformed steel reinforcing bars shall comply with A615 Grades 40 and 60 or ASTM A706 Grade 60 specifications for Zap Screwlok Type 2 and Transition Zap Screwlok couplers. Deformed steel reinforcing bars shall comply with ASTM A615 Grades 75 and 80 or ASTM A706 Grade 80 specifications for Zap Screwlok FX couplers.

4.4.3 Coatings: Zap Screwlok Type 2 and Transition couplers are available with an epoxy or galvanized coating, and Grade 60 reinforcing bar, sizes No. 4 through No. 11 may be epoxy coated in accordance with ASTM A775 or galvanized (zinc-coated) in accordance with ASTM A767.

5.0 IDENTIFICATION

5.1 The Barsplice Products, Inc. Mechanical Splice Systems are packaged in boxes, except for the BarSplicer XP system which is shipped with threaded bars (both with and without couplers on them) in bundles strapped to pallets.

5.2 Each individual coupler shall bear a label or permanent marking containing the product code and lot code designation matching the packaging label.



5.3 Packaging labels shall also be applied to either the box or the wrapped pallet containing the couplers, and shall include the manufacturer's name, address, the specific coupler system, quantity, size, product code, and lot number, the ACI 318 Type designation, and the evaluation report number (ER-796). The IAPMO Uniform Evaluation Service Mark of Conformity, as shown below, may also be used.



IAPMO UES ER-796

6.0 SUBSTANTIATING DATA

6.1 Data submitted in accordance with the Acceptance Criteria for Mechanical Splice Systems for Steel Reinforcing Bars (ICC-ES AC133).

6.2 Test reports submitted are from laboratories in compliance with ISO/IEC 17025.

7.0 STATEMENT OF RECOGNITION

This evaluation report describes the results of research completed by IAPMO Uniform Evaluation Service on Barsplice Products, Inc. Mechanical Splice Systems to assess conformance to the codes shown in Section 1.0 of this report and serves as documentation of the product certification. The systems are produced at locations noted in Section 2.17 of this report under a quality control program with periodic inspections under the supervision of IAPMO UES.

For additional information about this evaluation report please visit www.uniform-es.org or email us at info@uniform-es.org

TABLE 1 – BARGRIP XL DIMENSIONS

INCH SYSTEM				
BAR SIZE	LENGTH "L" (in)*	INSERTION "L/2" (in)*	OUTSIDE DIAMETER "OD" (in)*	INSIDE DIAMETER "ID" (in)*
#4	4	2	15/16	5/8
#5	4 3/4	2 3/8	1 1/8	3/4
#6	5 1/2	2 3/4	1 3/8	15/16
#7	6 1/4	3 1/8	1 9/16	1 1/16
#8	7	3 1/2	1 3/4	1 3/16
#9	7 1/2	3 3/4	1 15/16	1 3/8
#10	8 1/4	4 1/8	2 3/16	1 1/2
#11	9	4 1/2	2 3/8	1 11/16
#14	11	5 1/2	2 15/16	1 15/16
#18	14	7	3 13/16	2 5/8

SI UNITS SYSTEM				
BAR SIZE	LENGTH "L" (mm)*	INSERTION "L/2" (mm)*	OUTSIDE DIAMETER "OD" (mm)*	INSIDE DIAMETER "ID" (mm)*
13	102	51	24	16
16	121	60	29	19
19	140	70	35	24
22	159	79	40	27
25	178	89	44	30
29	191	95	49	35
32	210	105	56	38
36	229	114	60	43
43	279	140	75	50
57	356	178	97	67

* COUPLER DIMENSIONS ARE APPROXIMATE AS MEASURED BEFORE SWAGING ONTO THE REINFORCEMENT BAR.

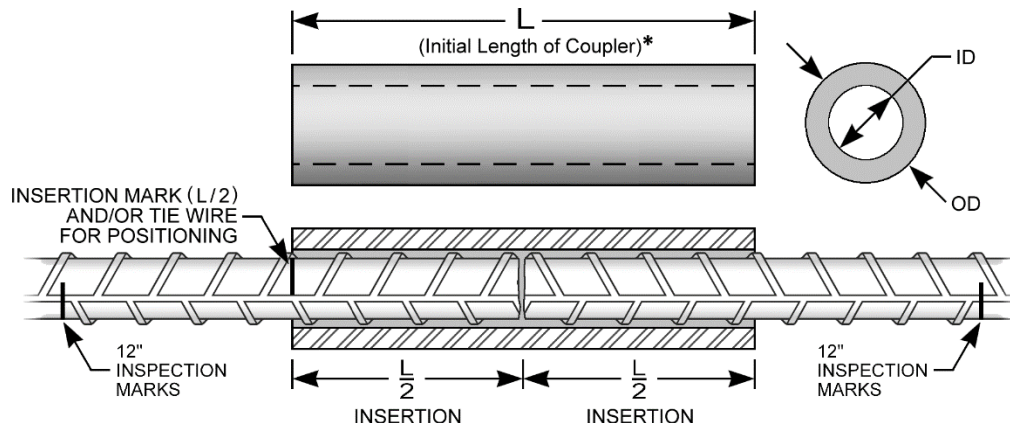

FIGURE 1 – BARGRIP XL



TABLE 2 – BARGRIP XL TRANSITION DIMENSIONS

INCH SYSTEM							SI UNITS SYSTEM						
TRANSITION BAR SIZES	LENGTH "L" (in)*	LARGER BAR			SMALLER BAR		TRANSITION BAR SIZES	LENGTH "L" (mm)*	LARGER BAR			SMALLER BAR	
		"OD _L " (in)*	"ID _L " (in)*	INSERTION "i" (in)*	"OD _S " (in)*	"ID _S " (in)*			"OD _L " (mm)*	"ID _L " (mm)*	INSERTION "i" (mm)*	"OD _S " (mm)*	"ID _S " (mm)*
5/4	4 1/4	1 1/16	3/4	1 11/16	7/8	5/8	16/13	108	27	19	43	22	16
6/5	5 1/4	1 3/8	15/16	2 1/16	1 1/16	3/4	19/16	133	35	24	52	27	19
7/6	5 7/8	1 9/16	1 1/16	2 7/16	1 3/8	15/16	22/19	149	40	27	62	35	24
8/7	6 1/2	1 3/4	1 3/16	2 7/8	1 9/16	1 1/16	25/22	165	44	30	73	40	27
9/8	7 5/8	1 15/16	1 5/16	3 1/4	1 3/4	1 3/16	29/25	194	49	33	83	44	30
10/9	8 1/8	2 3/16	1 1/2	3 7/16	1 15/16	1 5/16	32/29	206	56	38	87	49	33
11/9	8 1/2	2 3/8	1 5/8	3 1/2	1 15/16	1 5/16	36/29	216	60	41	89	49	33
11/10	8 1/2	2 3/8	1 5/8	3 1/2	2 3/16	1 1/2	36/32	216	60	41	89	56	38
14/11	10 1/8	2 7/8	1 15/16	3 7/8	2 3/8	1 5/8	43/36	257	73	49	98	60	41
18/11	11 9/16	3 13/16	2 5/8	4 1/8	2 3/8	1 5/8	57/36	294	97	67	105	60	41
18/14	11 9/16	3 13/16	2 5/8	4 1/8	2 7/8	1 15/16	57/43	294	97	67	105	73	49

* COUPLER DIMENSIONS ARE APPROXIMATE AS MEASURED BEFORE SWAGING ONTO THE REINFORCEMENT BAR.

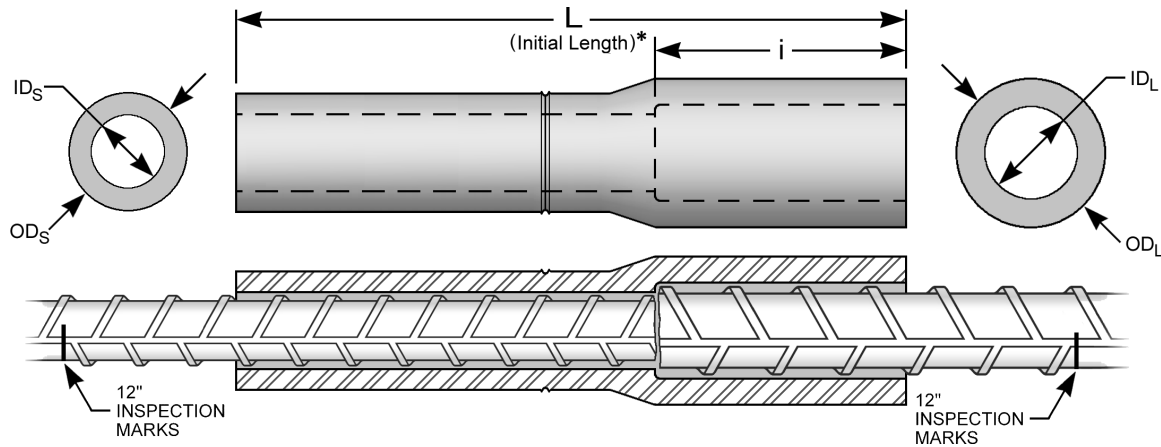

FIGURE 2 – BARGRIP XL TRANSITION

TABLE 3 – TAPER THREADED GRIP-TWIST® DIMENSIONS

INCH SYSTEM							SI UNITS SYSTEM						
BAR SIZE	LENGTH*		BAR INSERTION*		OUTSIDE DIA*	INSIDE DIA*	BAR SIZE	LENGTH*		BAR INSERTION*		OUTSIDE DIA*	INSIDE DIA*
	"L _M " (in)	"L _F " (in)	"i _M " (in)	"i _F " (in)	OD (in)	ID (in)		"L _M " (mm)	"L _F " (mm)	"i _M " (mm)	"i _F " (mm)	OD (mm)	ID (mm)
#4	2 15/16	2 15/16	1 3/4	1 3/4	7/8	5/8	13	75	75	45	45	22	15
#5	3 5/8	3 5/8	2 1/4	2 1/4	1 1/8	3/4	16	92	92	57	57	29	19
#6	4 5/16	4 5/16	2 5/8	2 5/8	1 3/8	15/16	19	110	110	67	67	35	24
#7	5	5	3 1/8	3 1/8	1 9/16	1 1/16	22	127	127	79	79	40	27
#8	5 5/8	5 5/8	3 1/2	3 1/2	1 3/4	1 3/16	25	143	143	89	89	45	30
#9	6 1/2	6 1/2	4	4	1 15/16	1 5/16	29	165	165	102	102	49	33
#10	7 1/4	7 1/4	4 3/8	4 3/8	2 3/16	1 1/2	32	184	184	111	111	56	38
#11	7 5/8	7 5/8	4 3/4	4 3/4	2 3/8	1 5/8	36	194	194	121	121	60	42
#14	9 3/8	9 3/8	6	6	2 7/8	1 15/16	43	238	238	152	152	73	49
#18	12 3/16	12 3/16	7 5/8	7 3/4	3 7/8	2 5/8	57	310	310	197	197	98	67

* COUPLER DIMENSIONS ARE APPROXIMATE AS MEASURED AFTER SWAGING ONTO THE REINFORCEMENT BAR.

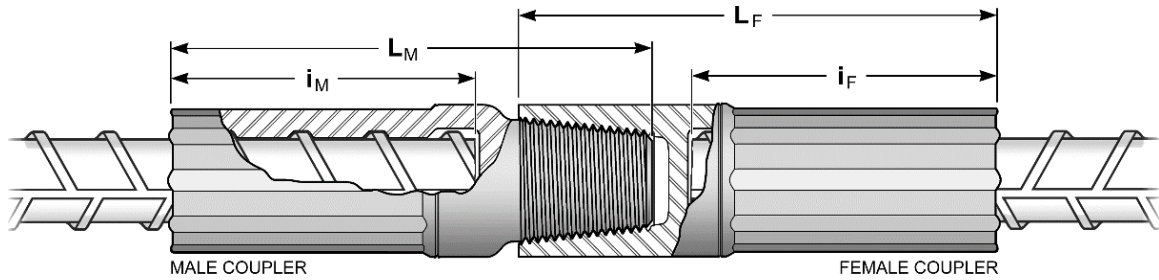

FIGURE 3 – TAPER THREADED GRIP-TWIST®

TABLE 4 – TAPER THREADED GRIP-TWIST® TRANSITION DIMENSIONS

INCH SYSTEM									SI UNITS SYSTEM								
TRANS. BAR SIZES	LENGTH*		BAR INSERTION*		OUTSIDE DIA*		INSIDE DIA*		TRANS. BAR SIZES	LENGTH*		BAR INSERTION*		OUTSIDE DIA*		INSIDE DIA*	
	"L _M " (in)	"L _T " (in)	"i _M " (in)	"i _T " (in)	OD _M (in)	OD _T (in)	ID _M (in)	ID _T (in)		"L _M " (mm)	"L _T " (mm)	"i _M " (mm)	"i _T " (mm)	OD _M (mm)	OD _T (mm)	ID _M (mm)	ID _T (mm)
5 / 4	2 15/16	3 5/8	1 3/4	2 1/4	7/8	1 1/8	5/8	3/4	16 / 13	75	92	45	57	22	28	15	19
6 / 5	3 5/8	4 5/16	2 1/4	2 5/8	1 1/8	1 3/8	3/4	15/16	19 / 16	92	110	57	67	28	35	19	24
7 / 6	4 5/16	5	2 5/8	3 1/8	1 3/8	1 9/16	15/16	1 1/16	22 / 19	110	127	67	79	35	40	24	27
8 / 7	5	5 5/8	3 1/8	3 1/2	1 9/16	1 3/4	1 1/16	1 3/16	25 / 22	127	143	79	89	40	45	27	30
9 / 8	5 5/8	6 1/2	3 1/2	4	1 3/4	1 15/16	1 3/16	1 5/16	29 / 25	143	165	89	102	45	49	30	33
10 / 9	6 1/2	7 1/4	4	4 3/8	1 15/16	2 3/16	1 5/16	1 1/2	32 / 29	165	184	102	111	49	56	33	38
11 / 9	6 1/2	7 5/8	4	4 3/4	1 15/16	2 3/8	1 5/16	1 5/8	36 / 29	165	194	102	121	49	60	33	42
11 / 10	7 1/4	7 5/8	4 3/8	4 3/4	2 3/16	2 3/8	1 1/2	1 5/8	36 / 32	184	194	111	121	56	60	38	42
14 / 11	7 5/8	7 1/8	4 3/4	4 1/4	2 3/8	2 7/8	1 5/8	1 15/16	43 / 36	194	181	121	108	60	73	42	49
18 / 11	7 5/8	8 3/8	4 3/4	5	2 3/8	3 7/8	1 5/8	2 5/8	57 / 36	194	213	121	127	60	98	42	67
18 / 14	9 3/8	8 3/8	6	5	2 7/8	3 7/8	1 15/16	2 5/8	57 / 43	238	213	152	127	73	98	49	67

* COUPLER DIMENSIONS ARE APPROXIMATE AS MEASURED AFTER SWAGING ONTO THE REINFORCEMENT BAR.

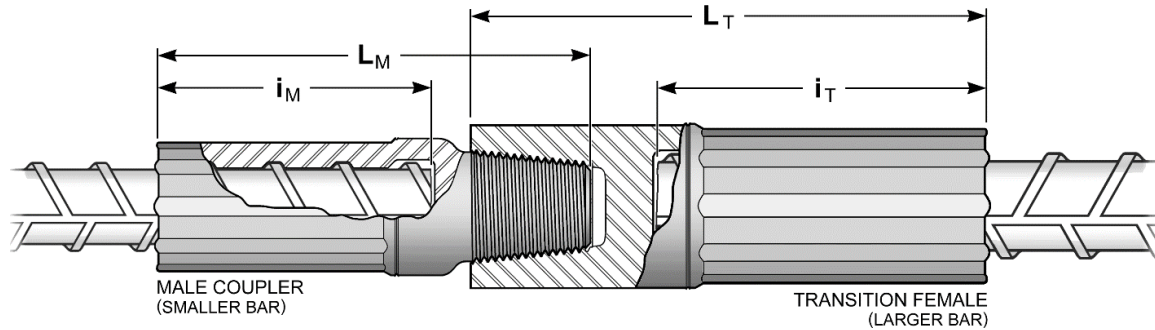

FIGURE 4 – TAPER THREADED GRIP-TWIST® TRANSITION



TABLE 5 – TAPER THREADED GRIP-TWIST® POSITION DIMENSIONS

INCH SYSTEM							SI UNITS SYSTEM						
BAR SIZE	LENGTH "L _P " (in)*	INSERTION "i _P " (in)*	OUTSIDE DIA. OD (in)*	INSIDE DIA. ID (in)*	TAPER MALE INSERTION "H" (in)	SPACE AFTER ASSY. "S" (in)	BAR SIZE	LENGTH "L _P " (mm)*	INSERTION "i _P " (mm)*	OUTSIDE DIA. OD (mm)*	INSIDE DIA. ID (mm)*	TAPER MALE INSERTION "H" (mm)	SPACE AFTER ASSY. "S" (mm)
#8	5 5/8	3 1/2	1 3/4	1 3/16	1 1/2	1 1/2	25	143	89	45	30	38	38
#9	6 1/2	4	1 15/16	1 5/16	1 3/4	1 5/8	29	165	102	49	33	45	41
#10	7 1/4	4 3/8	2 3/16	1 1/2	2	1 7/8	32	184	111	56	38	51	48
#11	7 5/8	4 3/4	2 3/8	1 5/8	2 1/8	1 3/4	36	194	124	60	42	54	45
#14	9 3/8	6	2 7/8	1 15/16	2 1/2	2 1/8	43	238	152	73	49	64	54
#18	12 3/16	7 3/4	3 7/8	2 5/8	3 1/4	2 1/8	57	310	197	98	67	83	54

* COUPLER DIMENSIONS ARE APPROXIMATE AS MEASURED AFTER SWAGING ONTO THE REINFORCEMENT BAR.

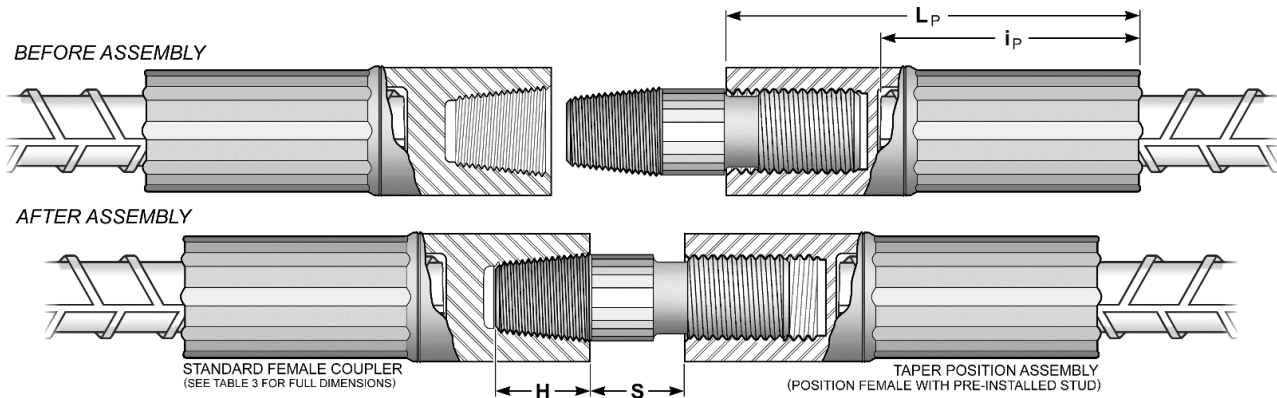

FIGURE 5 – TAPER THREADED GRIP-TWIST® POSITION

TABLE 6 – BARSPLICER XP COUPLER DIMENSIONS

INCH SYSTEM							SI UNITS SYSTEM						
BAR SIZE	THREAD SIZE	COUPLER WEIGHT (lb)	LENGTH "L" (in)	OUTSIDE "DIA" (in)	FLANGE "W" (in)	FLANGE "H" (in)	BAR SIZE	THREAD SIZE	COUPLER WEIGHT (kg)	LENGTH "L" (mm)	OUTSIDE "DIA" (mm)	FLANGE "W" (mm)	FLANGE "H" (mm)
#4	1/2 - 13 UNC	0.28	1 3/4	7/8	1 5/8	2 7/16	13	1/2 - 13 UNC	0.13	44	22	41	62
#5	5/8 - 11 UNC	0.35	2	1	1 5/8	2 7/16	16	5/8 - 11 UNC	0.16	51	25	41	62
#6	3/4 - 10 UNC	0.43	2 1/8	1 1/8	1 5/8	2 7/16	19	3/4 - 10 UNC	0.20	54	29	41	62
#7	7/8 - 9 UNC	0.54	2 1/2	1 1/4	2	2 15/16	22	7/8 - 9 UNC	0.24	64	32	51	75
#8	1 - 8 UNC	0.95	3	1 1/2	2	2 15/16	25	1 - 8 UNC	0.43	76	38	51	75
#9	1 1/8 - 7 UNC	1.63	3 1/2	1 3/4	2	2 15/16	29	1 1/8 - 7 UNC	0.74	89	45	60	86
#10	1 1/4 - 7 UNC	2.43	4	2	2 3/8	3 3/8	32	1 1/4 - 7 UNC	1.10	102	51	60	86
#11	1 3/8 - 6 UNC	2.54	4 1/2	2	2 3/8	3 3/8	36	1 3/8 - 6 UNC	1.15	114	51	60	86

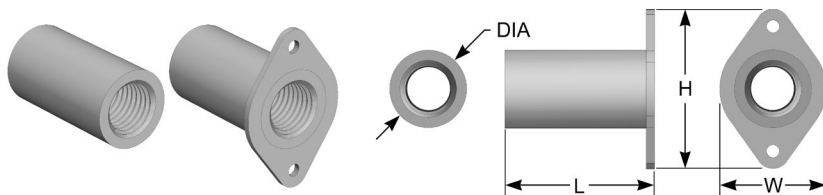

FIGURE 6 – BARSPLICER XP COUPLER AND FLANGE (OPTIONAL)



TABLE 7 – ZAP SCREWLOK® TYPE 2 DIMENSIONS

INCH SYSTEM							SI UNITS SYSTEM						
BAR SIZE	COUPLER WEIGHT (lbs)	Coupler Dimensions (in)			NUM. OF SCREWS PER BAR	(AVG) SCREW TORQUE (ft-lbs)	BAR SIZE	COUPLER WEIGHT (kg)	Coupler Dimensions (mm)			NUM. OF SCREWS PER BAR	(AVG) SCREW TORQUE (N-m)
		LENGTH "L"	"A" (AVG)	"B" (AVG)					LENGTH "L"	"A" (AVG)	"B" (AVG)		
#4	2.2	7	1 1/16	11/16	3	50	13	1.00	178	27	17	3	70
#5	3.4	9	1 1/8	3/4	4	50	16	1.54	229	29	19	4	70
#6	4.7	11	1 3/16	15/16	5	50	19	2.13	280	30	24	5	70
#7	7.6	13	1 1/4	1 1/16	5	100	22	3.45	330	32	27	5	140
#8	10.9	15 1/4	1 5/16	1 1/16	6	100	25	4.94	388	33	27	6	140
#9	17.6	16 3/4	1 5/8	1 1/4	6	200	29	7.98	426	41	32	6	280
#10	21.4	19 1/8	1 11/16	1 7/16	7	200	32	9.71	486	43	37	7	280
#11	25.4	21 1/2	1 13/16	1 1/2	8	200	36	11.5	546	46	38	8	280
#14	31.7	15 3/8	2 5/16	1 3/4	10	350	43	14.4	390	59	44	10	475
#18	74.0	29 1/2	2 1/2	2 3/8	21	350	57	33.6	749	64	60	21	475

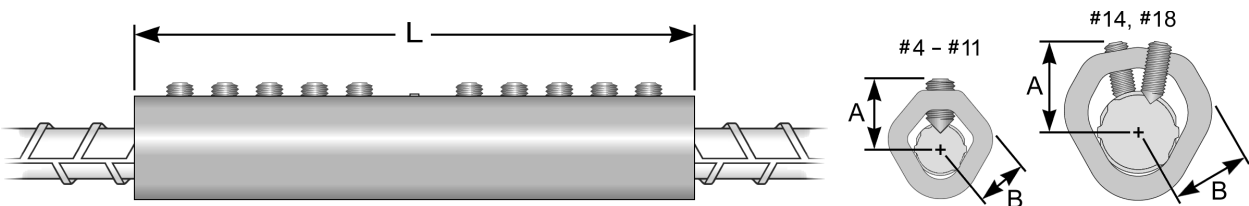

FIGURE 7 – ZAP SCREWLOK® TYPE 2

TABLE 8 – ZAP SCREWLOK® TRANSITION DIMENSIONS

INCH SYSTEM							SI UNITS SYSTEM						
TRANS. BAR SIZES	COUPLER WEIGHT (lbs)	Coupler Dimensions (in)			NUM. OF SCREWS PER BAR	(AVG) SCREW TORQUE (ft-lbs)	TRANS. BAR SIZES	COUPLER WEIGHT (kg)	Coupler Dimensions (mm)			NUM. OF SCREWS PER BAR	(AVG) SCREW TORQUE (N-m)
		LENGTH "L"	"A" (AVG)	"B" (AVG)					LENGTH "L"	"A" (AVG)	"B" (AVG)		
5/4	3.0	8	1 1/8	3/4	3	50	16/13	1.36	203	29	19	3	70
6/5	4.3	10	1 3/16	15/16	4	50	19/16	1.95	254	30	24	4	70
7/6	6.8	12	1 1/4	1 1/16	4	100	22/19	3.08	305	32	27	4	140
8/7	9.9	14 1/8	1 5/16	1 1/8	5	100	25/22	4.49	359	33	27	5	140
9/8	16.2	15 9/16	1 5/8	1 1/4	5	200	29/25	7.35	395	41	32	5	280
10/9	20.1	17 15/16	1 11/16	1 7/16	6	200	32/29	9.12	456	43	37	6	280
11/9	20.1	17 15/16	1 13/16	1 1/2	6	200	36/29	9.12	456	46	38	6	280
11/10	22.8	20 5/16	1 13/16	1 1/2	7	200	36/32	10.3	516	46	38	7	280

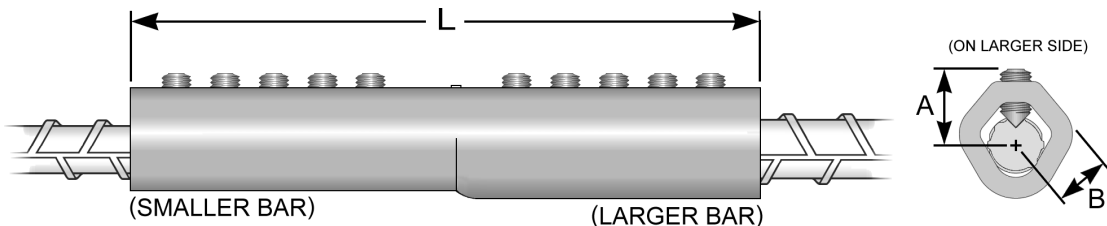

FIGURE 8 – ZAP SCREWLOK® TRANSITION



TABLE 9 – ZAP SCREWLOK® FX DIMENSIONS

INCH SYSTEM							SI UNITS SYSTEM						
BAR SIZE	COUPLER WEIGHT (lbs)	Coupler Dimensions (in)			NUM. OF SCREWS PER BAR	(AVG) SCREW TORQUE (ft-lbs)	BAR SIZE	COUPLER WEIGHT (kg)	Coupler Dimensions (mm)			NUM. OF SCREWS PER BAR	(AVG) SCREW TORQUE (N-m)
		LENGTH "L"	"A" (AVG)	"B" (AVG)					LENGTH "L"	"A" (AVG)	"B" (AVG)		
No.11	26	21 1/2	1 13/16	1 1/2	8	200	36	11.8	546	46	38	8	275
No.14	42	20 1/8	2 5/16	1 3/4	12	350	43	19.1	511	59	44	12	475
No.18	79	29 1/2	2 1/2	2 1/4	21	350	57	35.8	749	64	57	21	475

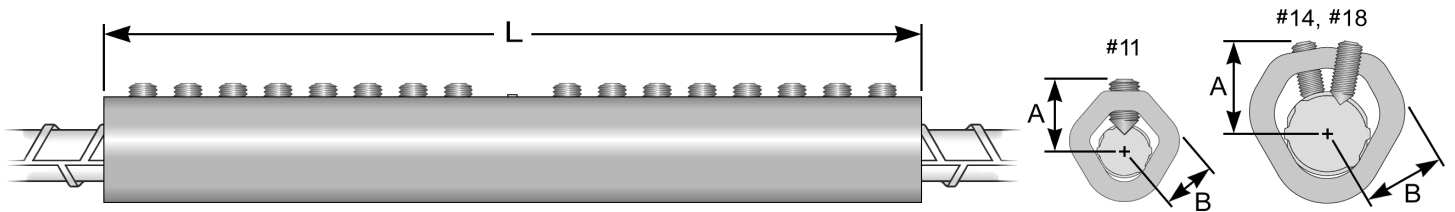

FIGURE 9 – ZAP SCREWLOK® FX



Originally Issued: 10/04/2021

Revised: 10/21/2024

Valid Through: 10/31/2026

CALIFORNIA BUILDING CODE SUPPLEMENT

BARSPlice PRODUCTS, INC.
4900 Webster Street
Dayton, OH 45414
937-275-8700
www.barsplice.com

BARSPlice PRODUCTS, INC. MECHANICAL SPLICE SYSTEMS FOR STEEL REINFORCING BARS:

- **BARGRIP (BPI-GRIP) XL
TRANSITION BARGRIP XL**
- **TAPER THREADED GRIP-TWIST®
TRANSITION TAPER THREADED
GRIP-TWIST®
POSITION TAPER THREADED GRIP-
TWIST®**
- **BARSPLICER XP**
- **ZAP SCREWLOK® TYPE 2
TRANSITION ZAP SCREWLOK®
ZAP SCREWLOK® FX**

CSI Section:

03 21 00 Reinforcing Steel

1.0 RECOGNITION

The Barsplice Products, Inc. Mechanical Splice Systems for steel reinforcing bars described in ER-796 and this CBC and CRC supplemental report have been evaluated for use as mechanical splices for deformed steel reinforcing bars (rebar) in concrete structural members. The Barsplice Products, Inc. Mechanical Splice Systems for steel reinforcing bars have been evaluated for structural performance properties, subject to the requirements in ER-796 and this CBC and CRC supplemental report. The Barsplice Products, Inc. Mechanical Splice Systems for steel reinforcing bars were evaluated for compliance with the following codes and regulations:

- 2022 and 2019 California Building Code (CBC)
- 2022 and 2019 California Residential Code (CRC)

2.0 LIMITATIONS

Use of the Barsplice Products, Inc. Mechanical Splice Systems recognized in this supplement is subject to the following limitations in addition to the limitations shown in ER-796 and the LA Supplement:

2.1 The Barsplice Products, Inc. Mechanical Splice Systems shall comply with the provisions applicable to the 2021 IBC or 2021 IRC (2022 CBC and CRC), or 2018 IBC or 2018 IRC (2019 CBC or 2019 CRC), as applicable, in ER-796.

2.2 Calculations and specifications verifying compliance with the Barsplice Products, Inc. Mechanical Splice Systems shall be submitted to the building official for approval at the time of permit application. The Barsplice Products, Inc. Mechanical Splice Systems calculations shall be prepared by a Civil or Structural Engineer registered in the State of California.

2.3 Periodic special inspection shall be provided in accordance with Section 1705.3 or 1705A.3 (California Department of Health Care Access and Information (HCAI) (formerly OSHPD) and Division of State Architect (DSA)) of the CBC during installations of the Barsplice Products, Inc. Mechanical Splice Systems.

2.4 Tests of reinforcing bars shall be provided in accordance with CBC Section 1909.2.4, 1910.2.2, or 1910A.2, as applicable.

2.5 The Barsplice Products, Inc. Mechanical Splice Systems shall be installed in accordance with the CBC or CRC, as applicable, manufacturer's installation instructions, and this supplement. A copy of the manufacturer's installation instructions shall be available on-site for the building official and special inspector. Where conflicts occur, the more restrictive shall govern.

2.6 For work in accordance with CBC Chapter 19A pertaining to DSA and HCAI (OSHPD), construction documents shall include the type and location of mechanical splices of reinforcement, as set forth in CBC Section 1901A.5.

2.7 For use in foundation walls, minimum concrete cover, and spacing between bars or sleeves shall be provided in accordance with Section 1808.8.2 or 1808A.8.2 of the CBC. Concrete cover and spacing shall be measured from the outer surface of the Barsplice Products, Inc. Mechanical Splice Systems.

2.8 Type 2 mechanical splices shall be provided in accordance with CBC 1905A.1.10 for DSA and HCAI (OSHPD) regulated structures.

2.9 This supplement expires concurrently with ER-796.

For additional information about this evaluation report please visit www.uniform-es.org or email us at info@uniform-es.org



CITY OF LOS ANGELES SUPPLEMENT

BARSPLICE PRODUCTS, INC.
4900 Webster Street
Dayton, OH 45414
937-275-8700
www.barsplice.com

BARSPLICE PRODUCTS, INC. MECHANICAL SPLICE SYSTEMS FOR STEEL REINFORCING BARS:

- **BARGRIP (BPI-GRIP) XL
TRANSITION BARGRIP XL**
- **TAPER THREADED GRIP-TWIST®
TRANSITION TAPER THREADED
GRIP-TWIST®
POSITION TAPER THREADED GRIP-
TWIST®**
- **BARSPLICER XP**
- **ZAP SCREWLOK® TYPE 2
TRANSITION ZAP SCREWLOK®
ZAP SCREWLOK® FX**

CSI Section:
03 21 00 Reinforcing Steel

1.0 RECOGNITION

The Barsplice Products, Inc. Mechanical Splice Systems for steel reinforcing bars described in ER-796, the California supplement, and this supplemental report have been evaluated for use as mechanical splices for deformed steel reinforcing bars (rebar) in concrete structural members. The Barsplice Products, Inc. Mechanical Splice Systems for steel reinforcing bars have been evaluated for structural performance properties, subject to the requirements in ER-796 and this supplemental report. The Barsplice Products, Inc. Mechanical Splice Systems for steel reinforcing bars were evaluated for compliance with the following codes and regulations:

- 2020 City of Los Angeles Building Code (LABC)
- 2020 City of Los Angeles Residential Code (LARC)

2.0 LIMITATIONS

Use of the Barsplice Products, Inc. Mechanical Splice Systems for steel reinforcing bars recognized in this supplement is subject to the following limitations:

2.1 Continuous special inspections of the mechanical splicing systems during installation shall be provided by Registered Deputy Inspectors as required by Section 1705 of the 2020 LABC, as applicable. The Registered Deputy Inspector shall verify the following: hardware and equipment; cleaning and condition of the bars in accordance with the specifications and the applicable code; and the installation procedures

comply with the specifications and the manufacturer's published installation instructions.

2.2 The fabricator of the steel couplers shall be required to maintain a detailed procedure for material control and suitable procedures and records attesting that the specified coupler has been furnished. The applicable splice designation (Type 1 or Type 2) or coating, as applicable, shall be included in each packaging assembly prior to shipment from the fabricator's plant. The fabricator's identification mark designation shall be established and on record prior to fabrication. Couplers that are not identifiable from marking and test records shall be tested to determine conformity to this report. The fabricator shall furnish an affidavit of compliance and test data shall be provided upon request.

2.3 The Barsplice Products, Inc. Mechanical Splice Systems shall be selected at the job site by the Registered Deputy Inspector or by the building inspector and shall be tested by an approved testing agency in accordance with Section 1703 of the LABC. The test shall be conducted on each different rebar size and the frequency of tests shall be as follows: one out of the first ten splices; one out of the next ninety splices; one out of the next one hundred splices. The splice shall develop in tension or compression, as required, at least 125 percent of the specified yield strength of the bar as per Section 25.5.7.1 of ACI 318-19 and -14. For Type 2 splices, the splice shall develop at least 100 percent of the specified tensile strength of the steel reinforcing bar.

For Type 2 splices only, if failure of the tested splice should occur prior to obtaining the 125 percent of the specified yield strength and the 100 percent of the specified tensile strength, then 25 percent of all couplers shall be tested for both specified yield strength and specified tensile strength. If failure of the tested Type 2 splice occurs with testing of the 25-percent requirement, as stated above, then all couplers shall be rejected.

2.4 Minimum concrete cover and spacing between bars or sleeves shall be provided in accordance with Section 1808.8.2 of the 2020 LABC.

2.5 The Barsplice Products, Inc. Mechanical Splice Systems for steel reinforcing bars shall be installed in accordance with the applicable code, manufacturer's installation instructions, and this supplement. A copy of the manufacturer's installation instructions or specifications shall be available on-site for all Registered Deputy Inspectors.

2.6 Splice locations shall be noted on the plans approved by the building official.

2.7 Only qualified operators, specified by the manufacturer, completely familiar with the installation procedures and specifications, shall perform the splicing.

2.8 This supplement expires concurrently with ER-796.

For additional information about this evaluation report please visit www.uniform-es.org or email us at info@uniform-es.org